

# GES FOUNDRY PRODUCTS METALLURGY

## (KX K TYPE EXOTHERMIC FEEDER)

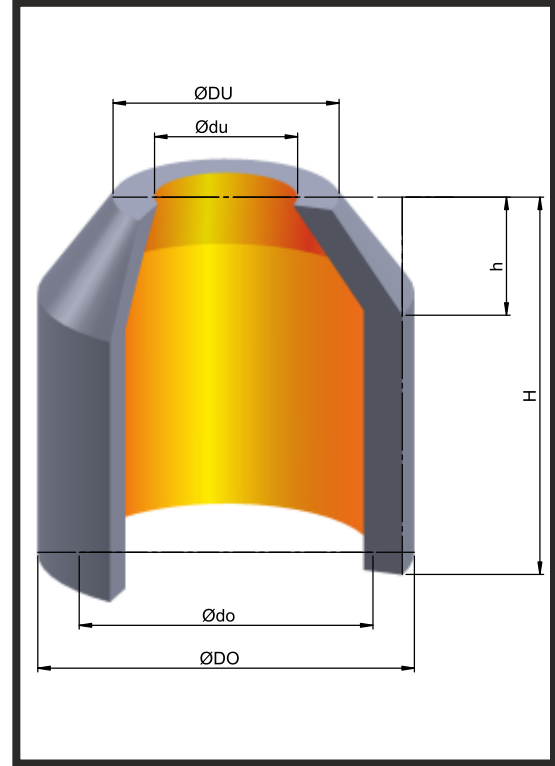
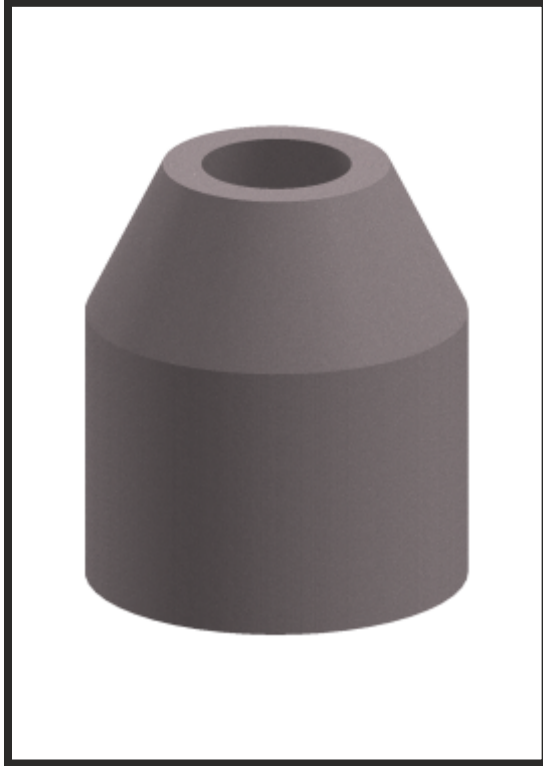

TYPE	MODULE	(cm)	DIMENSIONS(mm)						VOLUME dm <sup>3</sup>
			GEOM	Ødu	ØDu	Ødo	ØDo	h	
KXK0	1,50	1,00	30	55	50	75	15	100	0,18
KXK0/150	1,61	1,07	34	55	50	75	15	150	0,36
KXK1	2,10	1,40	38	69	78	100	27	100	0,41
KXK1/150	2,20	1,45	38	69	78	100	27	150	0,46
KXK2	2,30	1,50	45	74	85	114	34	100	0,48
KXK2/150	2,50	1,70	45	74	87	115	34	150	0,81
KXK3	2,70	1,80	48	76	94	130	43	150	0,93
KXK4	3,20	2,10	60	97	118	157	50	150	1,40
KXK4.5	3,60	2,40	65	109	135	177	65	180	2,16
KXK5	4,10	2,70	70	120	147	192	68	195	3,00
KXK5,5	4,40	2,90	80	128	165	211	80	225	4,05
KXK6	4,80	3,20	87	132	175	222	90	250	5,10
KXK7	5,10	3,50	100	150	200	250	100	250	6,50
KXK8	5,50	3,80	110	160	225	278	110	250	8,00
KXK9	6,20	4,30	124	180	252	310	120	300	12,20
KXK10	7,00	4,80	150	210	300	360	140	300	17,00
KXK11	7,70	5,30	175	240	355	410	155	300	22,60